

201



# **DTSD1352**

安装使用说明书 V2.4

Installation and operation instruction V2.4

安科瑞电气股份有限公司

ACREL Co.,Ltd

## 申明 Declare

版权所有，未经本公司之书面许可，此手册中任何段落、章节内容均不得摘抄、拷贝或以任何形式复制、传播，否则一切后果由违者自负。

本公司保留一切法律权利。

The copyright is the property of Acrel. Any information in any paragraph or section cannot be extracted, copied or otherwise reproduced or propagated. Otherwise offenders shall take all consequences.

All rights are reserved.

本公司保留对本手册所描述之产品规格进行修改的权利，恕不另行通知。订货前，请垂询当地代理商以获悉本产品的最新规格。

Acrel reserves the right to modify the product specifications herein without notification. Please consult the local agent about the latest specifications before placing a purchase order.

# 目录 Content

1 概述 General.....	1
2 型号说明 Type description.....	1
3 产品功能 Function description.....	1
4 技术参数 Technical parameter.....	3
5 外形尺寸 Outline.....	4
6 接线与安装 Wiring and installing.....	4
7 主要功能特点 Function description.....	9
8 操作与显示 Operation and display.....	10
9 通信说明 Communication description.....	14

## 1 概述 General

DTSD1352 导轨式多功能电能表，是主要针对电力系统，工矿企业，公用设施的电能统计、管理需求而设计的一款智能仪表，产品具有精度高、体积小、安装方便等优点。集成全部电力参数测量及全面的电能计量及考核管理，提供上 12 月的各类电能数据统计。具有 31 次分次谐波与总谐波含量检测，带有开关量输入和开关量输出可实现“遥信”和“遥控”功能，并具备报警输出。带有 RS485 通信接口，可选用 MODBUS-RTU。该电力仪表可广泛应用于各种控制系统，SCADA 系统和能源管理系统中。性能指标符合国标 IEC62053-21、IEC62053-22 对电能表的各项技术要求。

DTSD1352 is a smart meter designed for power supply system, industrial and mining enterprises and utilities to calculate the electricity consumption and manage the electric demand. It features the high precision, small size and simple installation. It integrates the measurement of all electrical parameters with the comprehensive electricity metering and management provides various data on previous 12 months, checks the 31st harmonic content and the total harmonic content, realizes the remote communication and the remote control with switching input and relay output and boasts the alarm output. It is fitted with RS485 communication port and adapted to MODBUS-RTU. DTSD1352 can be used in all kinds of control systems, SCADA systems and energy management systems. All meters meet the related technical requirements of electronic power meter in the IEC62053-21、IEC62053-22 standards.

## 2 型号说明 Type description

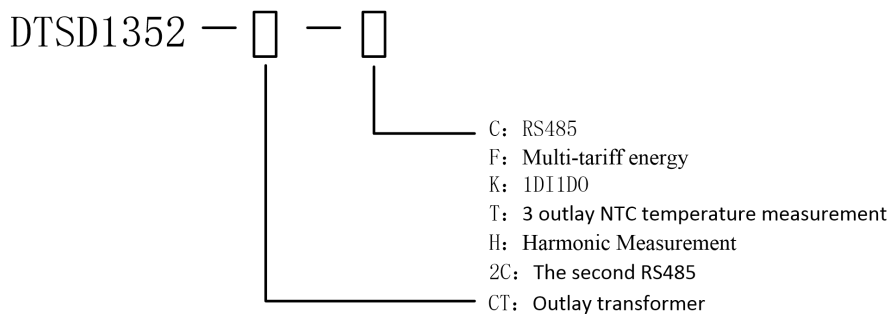

## 3 产品功能 Function description

功能 Function	功能说明 Function description	功能配置 Function provide
电能计量 Measurement of kWh	有功电能计量（正、反向） Active kWh (positive and negative)	■
	无功电能计量（正、反向） Reactive kWh (positive and negative)	■
	A、B、C 分相正向有功电能	■

	A, B, C phase positive active kWh	
电量测量 Measurement of electrical parameters	U、IP、Q、S、PF、F	■
		■
谐波测量 Measurement of	2~31 次谐波电压电流 2~31 <sup>ST</sup> Voltage and current harmonic	<input type="checkbox"/> 注 Note 1
LCD 显示 LCD Display	8 位段式 LCD 显示、背光显示 8 bits section LCD display, background light	■
按键编程 Key programming	4 按键可编程通信、变比等参数 4 keys to communication and set parameters	■
脉冲输出 Pulse output	有功脉冲输出 Active pulse output	■
	无功脉冲输出 Reactive pulse output	<input type="checkbox"/> 注 Note 2
	时钟脉冲输出 Clock pulse output	<input type="checkbox"/> 注 Note 2
LED 报警 LED alarm	失压、过压报警 Alarm on voltage loss and overvoltage	■
复费率及附带功能 Multi-tariff and functions	有源开关量输入 Active switch input	<input type="checkbox"/> 注 Note 3
	开关量输出 Switch output	<input type="checkbox"/> 注 Note 2
	支持 4 个时区、2 个时段表、 14 个日时段、4 个费率 Adapt 4 time zones, 2 time interval lists, 14 time interval by day and 4 tariff rates	<input type="checkbox"/>
	最大需量及发生时间 Max demanded kWh and time happened	<input type="checkbox"/>
	上 48 月、上 90 日历史冻结数据 Frozen data on last 48 months, last 90days	<input type="checkbox"/>
	日期、时间 Date, time	<input type="checkbox"/>
通讯 Communication	红外通讯 Infrared communication	■
	第一路通讯: RS485 接口, 支持 Modbus The first communication path: Communication interface: RS485, Communication protocol: MODBUS-RTU	<input type="checkbox"/>
	第二路通讯: RS485 接口, 支持 Modbus The second communication path: Communication interface: RS485, Communication protocol: MODBUS-RTU	<input type="checkbox"/> 注 Note 3

测温 Temperature measurement	支持 3 外置 NTC 测温 Support 3 outlay NTC temperature	<input type="checkbox"/> 注 Note 4
----------------------------------	--	-----------------------------------

“■”表示标配, “□”表示选配 “■” means standard, “□” means optional

注: 1: 外置互感器规格时, 谐波测量为标配, 其余规格均为选配。

- 2: 默认无功脉冲、时钟脉冲、开关量输出三选一;
- 3: 有源开关量和第二路通讯二选一;
- 4: 选配测温功能时 1、2 所述选配功能均不可选。

Note:

1: Harmonic is a standard while choosing outlay transformer, optional for other situation.

2: Reactive pulse output, clock pulse output and switching output: Choose one of these three.

3: Active switching, the second communication path: Choose one of these two.

4: Both 1 and 2 cannot be chosen while choosing temperature measurement.

## 4 技术参数 Technical parameter

规格 Specification	三相三线、三相四线 3 phase 3 wires, 3 phase 4 wires	
电压 Voltage	参比电压 Reference voltage	3×100V、3×380V、3×57.7/100V、3×220/380V
	功耗 Consumption	<10VA(单相)(Single phase)
	阻抗 Impedance	>2MΩ
	精度等级 Accuracy class	误差 Error±0.2%
电流 Current	输入电流 Input current	3×1(6)A, 3×1(6)A(互感器外置)(Outlay transformer), 3×10(80)A
	功耗 Consumption	<1VA(单路额定电流)(Single phase rated current)
	精度等级 Accuracy class	误差 Error±0.2%
功率 Power	有功、无功、视在功率, 误差±0.5% Active, reactive, apparent power, error±0.5%	
电网频率 Frequency	45~65Hz, 误差 Error±0.2%	
温度 Temperature	-40℃~99℃	
电能 Energy	有功电能(准确度等级 0.5S 级, 1 级) 无功电能(准确度等级 2 级) Active energy(Accuracy class:0.5, 1), reactive energy(Accuracy class 2)	
时钟 Clock	≤0.5s/d	
电量脉冲输出 Energy pulse output	1 路有功光耦输出、1 路无功光耦输出 1 active optocoupler output, 1 reactive optocoupler output	
开关量输出 Switching output	1 路开关量输出 1 Switching output	
开关量输入 Switching input	1 路光耦输入 1 optocoupler input	
脉冲宽度	80±20ms	

Width of pulse	
脉冲常数 Pulse constant	6400imp/kWh,400imp/kWh（与基本电流对应）(Correspond with the basic current)
接口与通信规约 Interface and communication	RS485: Modbus RTU
通信地址范围 Range of communication address	Modbus RTU:1~ 247;
波特率 Baud rate	1200bps~19200bps
工作温度 Relative temperature	-25℃~+55℃
相对湿度 Relative humidity	≤95%（无凝露）(No condensation)

## 5 外形尺寸 Dimension drawings



图 1 经互感器接入 connect via CT



图2 直接接入 direct connect

注：直接接入的接线力矩不应大于  $4.0N \cdot m$ ，经互感器接入的接线力矩应不大于  $2.0N \cdot m$ 。

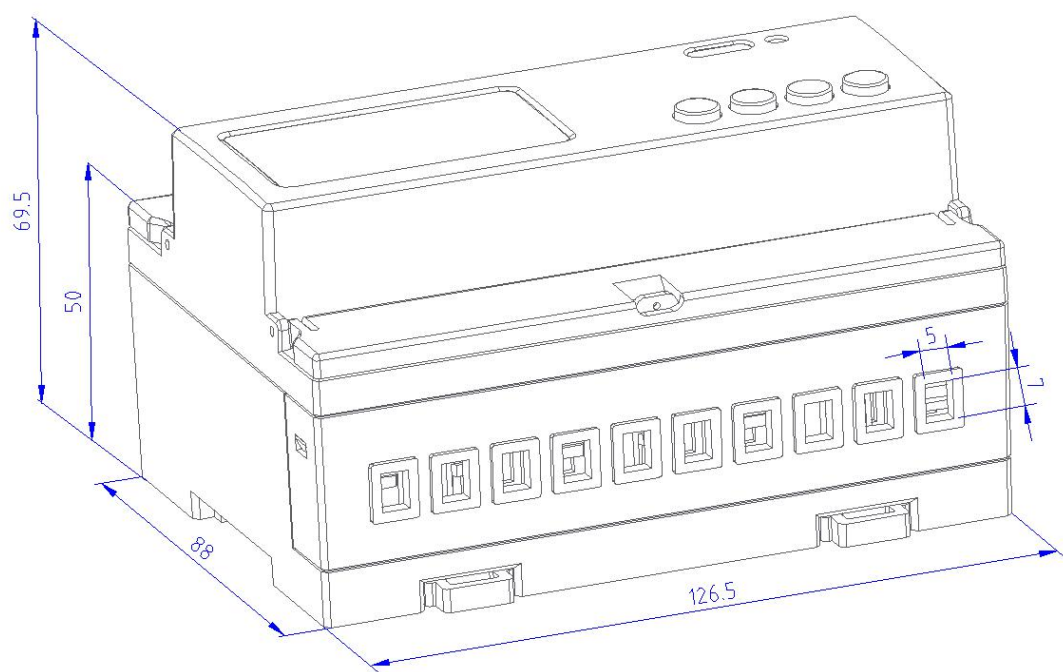
Note: The torque of direct connect should not be greater than  $4.0N \cdot m$ , and the torque of connect via CT should not be greater than  $2.0N \cdot m$ .

## 6 接线与安装 Wiring and installing

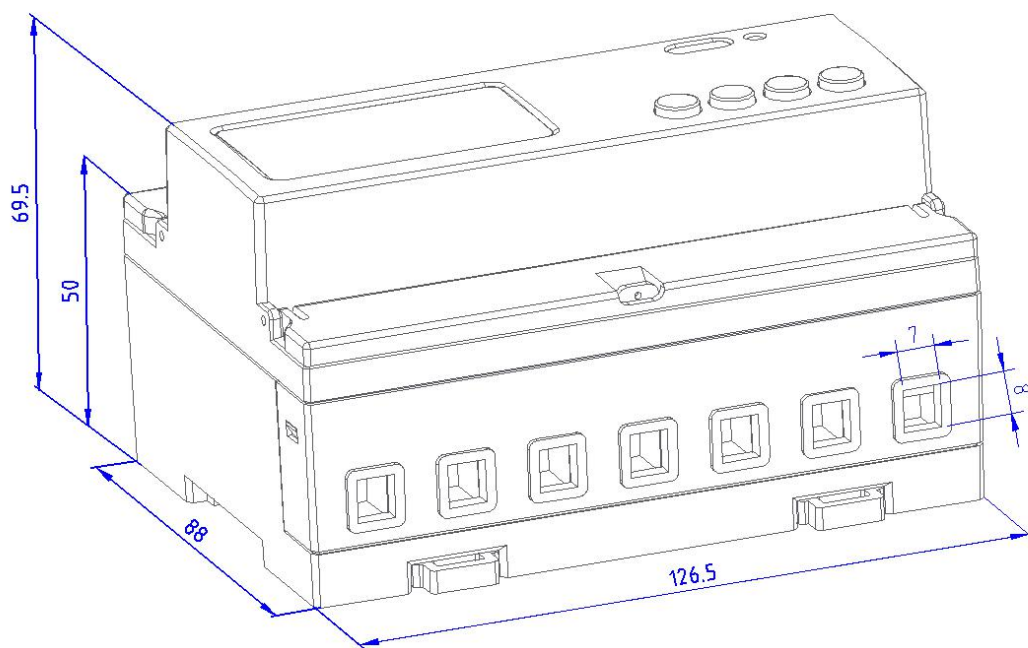
### 6.1 电压电流接线示意图 Wiring sample of voltage and current



图2 三相四线经互感器接入

Fig 2 Three phase four lines connect via CT



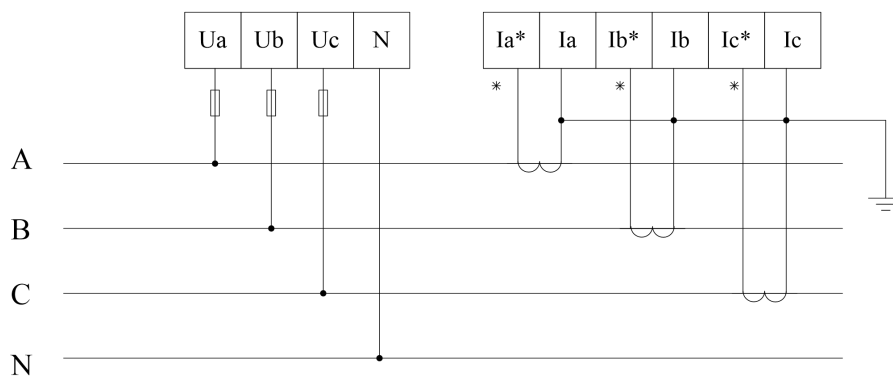

图 3 三相四线直接接入

Fig 3 Three phase four lines direct connect

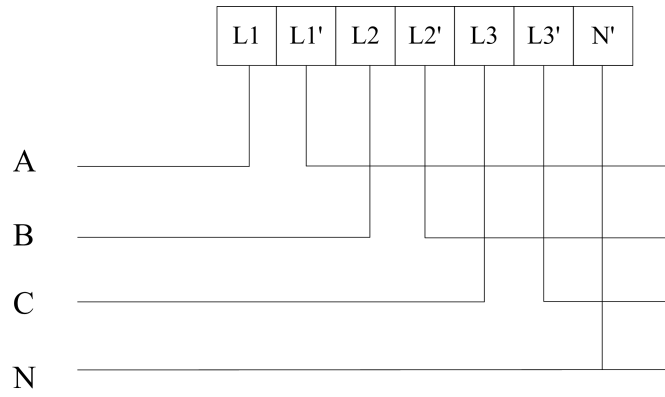

图 4 三相三线经互感器接入

Fig 4 Three phase three lines connect via CT

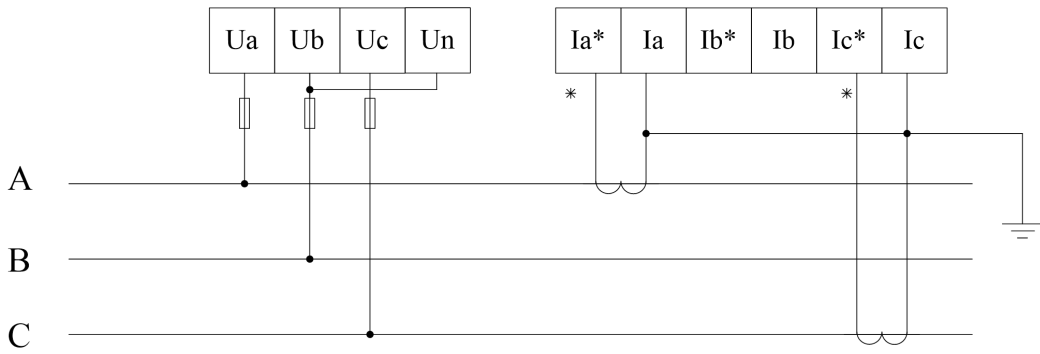

图 5 三相三线直接接入

Fig 5 Three phase three lines direct connect

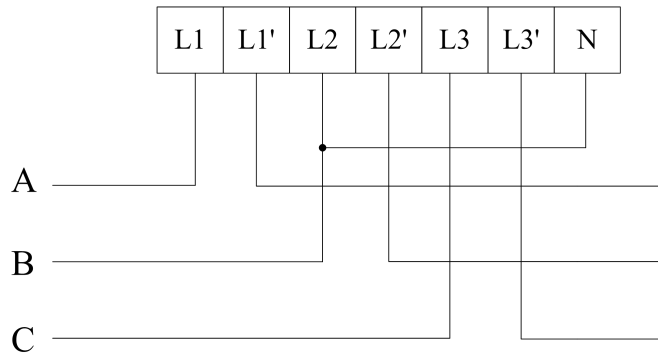

图 6 三相四线 3CT

Fig 6 Three phase four lines, 3CT

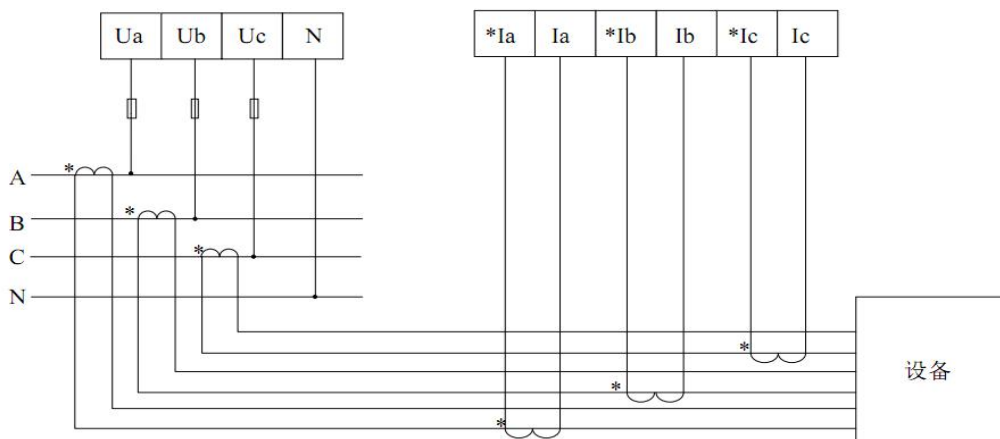

图 7 三相三线 2CT

Fig 7 Three phase three lines, 2CT

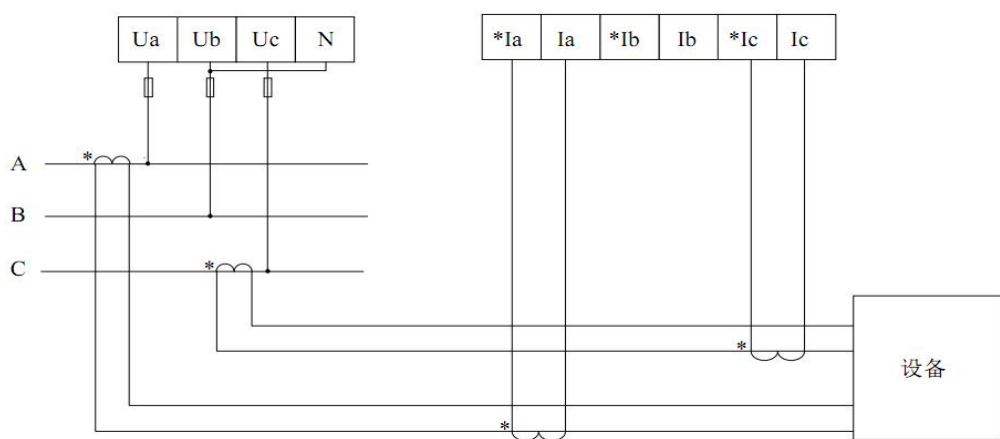

图 8 互感器外形尺寸

Fig 8 Outline of transformer

注：接线方式为下进下出。

Note: The method of wiring is: input downward and output downward.

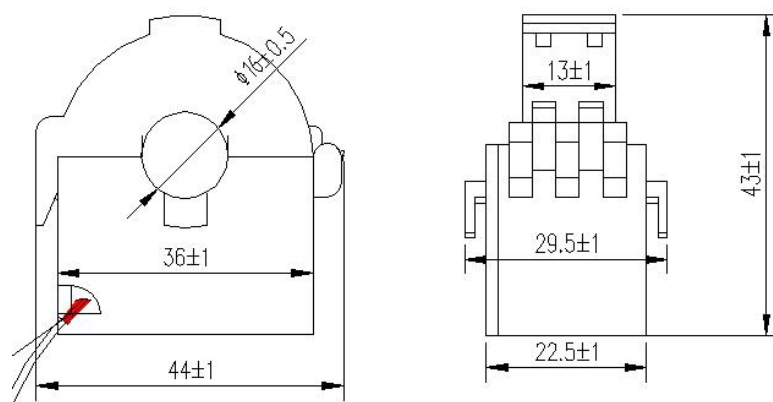
## 6.2 开关量输入、输出、NTC 测温端子

## Switching input, output, NTC temperature measurement.



图 9 通讯、脉冲接线

Fig 9 Communication, pulse connection

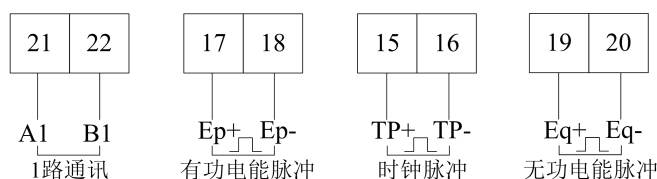

图 10 通讯、开关量接线

Fig 10 Communication, pulse connection

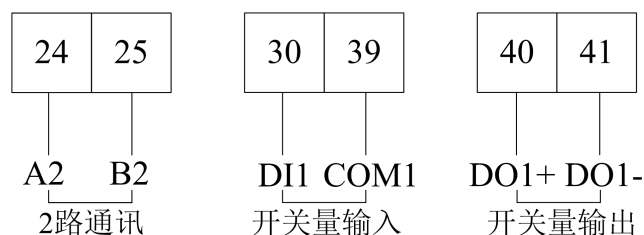

图 11 外置 NTC 测温

Fig 11 Outlay NTC temperature measurement

开关量输出为继电器输出，可实现“遥控”和报警输出。

开关量输入是采用开关信号输入方式，由外部电源供电。当外部接通或断开时，经过仪表开关输入模块采集其接通或断开信息并通过仪表本地显示。开关量输入不仅能够采集和显示本地的开关信息，同时可以通过仪表的 RS485 实现远程传输功能，即“遥信”功能。

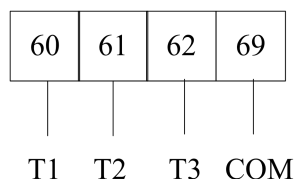
Switching output is relay output, can achieve the remote-control and alarm output.

The switch input adapts the method of on-off signal input and powered by outer power supply. It can be gotten by meter when there is a change of on or off via a switching input module. The parameter of switching input can not only get and show the state of local switching information but also achieve the communication via RS485, which called “remote information” function.

注：（17-18）为有功电能脉冲，（60-61-62-69）为三路 NTC 测温端口，（15-16）时钟脉冲、（19-20）无功电能脉冲、（40-41）开关量输出与（60-61）端子复用，（24-25）2路通讯、（31-39）开关量输入与（62-69）端子复用。

Note: (17-18) are active energy pulse, (60,61,62,69) are NTC temperature measurement port, (15,16) are clock pulse, (19,20) are reactive energy pulse, (40,41) are switch output and multiplex with (60,61), (24,25) are 2 path of communication, (31,32) are switch input and multiplex with (62,69).

## 7 主要功能特点 Function description

### 7.1 测量功能 Measurement

能测量全电力参数包括电压 U、电流 I、有功功率 P、无功功率 Q、视在功率 S、功率因数 PF、频率、31 次分次谐波及总谐波含量。其中电压 U 保留 1 位小数，频率 F 保留 2 位小数，电流 I 保留 2 位小数，功率 P 保留 3 位小数。

如：U = 220.1V, f = 49.98Hz, I = 1.99A, P = 0.439kW

The meter can measure all electrical parameters such as voltage, current, active power, reactive power, apparent power, power factor, frequency, 31<sup>st</sup> harmonic and total harmonic. The value format of voltage, current, frequency and power are listed as below.

Example: U = 220.1V, f = 49.98Hz, I = 1.99A, P = 0.439kW

### 7.2 计量功能 Calculating

能计量当前组合有功电能，正向有功电能，反向有功电能，正向无功电能，反向无功电能。

The meter can calculate the current active energy, forward active energy, reversing active energy, forward reactive energy and reversing reactive energy.

### 7.3 分时功能 Timing

两套时段表，一年可以分为 4 个时区，每套时段表可设 8 个日时段，4 个费率(F1、F2、F3、F4 即尖峰平谷)。分时计费的基本思想就是把电能作为一种商品，利用经济杠杆，用电高峰期电价高，低谷时电价低，以便削峰填谷，改善用电质量，提高综合经济效益。

The meter has 2 time lists, and can be divided into 4 time zones per year. Each time list can be divided into 8 time periods and 4 tariff (F1、F2、F3、F4). The main purpose of multi-tariff is promote the energy efficiency and economic benefits.

### 7.4 需量功能 Demand

有关需量的相关概念如下：

There are some definitions on demand:

需 量 Demand	需量周期内测得的平均功率叫需量 The average power in the demand cycle.
最大需量 Maximum demand	在指定的时间区内需量的最大值叫最大需量 The maximum value of demand in a period of time.
滑差时间 Slip time	从任意时刻起，按小于需量周期的时间递推测量需量的方法，所测得的需量叫滑差式需量。递推时间叫滑差时间
需量周期 Demand cycle	连续测量平均功率相等的时间间隔，也叫窗口时间 The time period between two same average value of demand.

缺省需量周期为 15 分钟，滑差时间为 1 分钟。

能测量 4 种最大需量即正向有功、反向有功、感性无功、容性无功最大需量以及最大需量发生的时间。

The default demand cycle is 15 minutes, slip time is 1 minute.

The meter can measure 4 kinds of maximum demand: forward active, reversing active, inductance performance reactive, capacitance performance reactive maximum demand and the

occur time.

## 7.5 历史数据统计功能 History data statistics

能统计上 48 月的历史电能（各费率电能）和上 90 日的历史电能（各费率电能）。  
The meter can record last 48 months or last 90 days history energy in each tariff.

## 7.6 开关量输入输出功能 Switching input and output

有一路开关量输出，一路开关量输入，开关量输出为继电器输出，可以实现“遥控”和报警输出。开关量输入不仅能够采集和显示本地的开关信息，同时可以通过仪表的 RS485 实现远程传输功能，即“遥信”功能。

The switch input adapts the method of on-off signal input and powered by outer power supply. It can be gotten by meter when there is a change of on or off via a switching input module. The parameter of switching input can not only get and show the state of local switching information but also achieve the communication via RS485, which called “remote information” function.





## 7.7 测温功能 Temperature measurement

支持三路外置 NTC 测温功能，测温范围为-40℃~99℃。

The meter support three path of outlay NTC temperature measurement, the range of temperature is -40℃~99℃.

# 8 操作与显示 Operation and display

## 8.1 按键功能说明 Key function description

按键图标 Key symbol	按键名称 Key name	按键功能 Function
	菜单键 Menu	进入/退出菜单 Enter/quit menu
	电压电流类，向上键 Voltage and current, up	查看界面中查看电压电流 编程界面中左移及闪烁移位 Check the voltage and current Leftward and change flash in programming menu
	功率类，向下键 Power, down	查看界面中查看功率 编程界面中右移及修改闪烁位 Check the power Rightward and change the value on flash
	电能类，编程确定键 Energy, enter	查看界面中查看电能 编程界面中确定保存设置 Check the energy Enter in programming menu

## 8.2 显示界面 Display menu

上电后显示正向有功电能。可通过三类查看键实现翻页显示。各类显示界面顺序说明如下：

The meter will show the forward active energy after powering. The customers can change the information showing by pressing the keys. The menu description is listed as below:

	<p>A 相电压、B 相电压、C 相电压、A 相电流、B 相电流、C 相电流、频率、日期、时间、通信地址、软件版本号、全显检测；</p> <p>Voltage on A, B, C phase, Current on A, B, C phase, Frequency, Date, Time, Address, Version, Test on display</p>
	<p>A 相有功功率、B 相有功功率、C 相有功功率、总有功功率、A 相无功功率、B 相无功功率、C 相无功功率、总无功功率、A 相视在功率、B 相视在功率、C 相视在功率、总视在功率、A 相功率因数、B 相功率因数、C 相功率因数、总功率因数、正向有功最大需量、反向有功最大需量、正向无功最大需量、反向无功最大需量；</p> <p>Total active/reactive/apparent power and on A, B, C phase, Total power factor and on A, B, C phase, Forward/reversing active/reactive maximum demand</p>
	<p>正向有功总电能、反向有功总电能、正向无功总电能、反向无功总电能、正向有功尖电能、正向有功峰电能、正向有功平电能、正向有功谷电能、反向有功尖电能、反向有功峰电能、反向有功平电能、反向有功谷电能、正向无功尖电能、正向无功峰电能、正向无功平电能、正向无功谷电能、反向无功尖电能、反向无功峰电能、反向无功平电能、反向无功谷电能、A 相正向有功电能、B 相正向有功电能、C 相正向有功电能。</p> <p>Total forward/reserving active/reactive energy, forward/reserving active/reactive spike/peak/flat/valley energy, forward active energy on A, B, C phase.</p>

说明：

1、以上所列为 DTSD1352 三相四线带有复费率功能的仪表所有显示界面名称，三个按键可切换不同类型的显示内容，切换顺序如上所述；

2、对于 DTSD1352 三相三线的仪表，不显示分相功率与功率因数，只有总功率（有功、无功、视在）和总功率因数。

3、对于 DTSD1352 不带有复费率功能的仪表，不显示日期、时间、各类最大需量及各类的分时电能（即尖、峰、平、谷四种费率时段的电能）。

Note:

1 All the display menus above are in the model of DTSD1352 three phases four lines with multi-tariff rate function and can be changed by the keys.

2 There will not be power or power factor on each phase and will only show total power and power factor (Active, reactive, apparent) under the three phase three lines.

3 There will not be date, time, maximum demand and energy by time without the function of multi-tariff rate.



当前正向有功总电量 12.34kWh

Current forward active energy 12.34kWh



当前反向有功总电量 12.34kWh

Current reversing active energy 12.34kWh



当前正向无功总电量 12.34kvarh

Current forward reactive energy 12.34kWh



当前正向有功尖电量 12.34kWh

Current forward active energy 12.34kWh



当前总功率 1.234kW

Current power is 1.234kW



当前正向有功需量 1.234kW

Current forward active demand is 1.234kW



当前 A 相电压为 123.4V

Voltage on A phase is 123.4V



当前 A 相电流为 12.34A

Current on A phase is 12.34A



当前 T1 温度为 25.5 摄氏度

Temperature on T1 is 25.5 cent degree



当前 T2 温度为 25.5 摄氏度

Temperature on T2 is 25.5 cent degree

当前 T3 温度为 25.5 摄氏度

Temperature on T3 is 25.5 cent degree

注：以上只是显示界面的一部分，其他界面显示模式与上图类似，可根据界面中显示的信息来判断显示含义。



Note: There are parts of the display function, and other menus are familiar with the example above. The customers can understand the meaning refer to the above examples.

### 8.3 编程界面 Key Menu

在测量显示菜单中的任一显示项下，按 **SET** 可进入“PASS”界面，再按 **↩** 显示“0000”，提示输入密码后再按 **↩**，若密码输入错误，则返回“0000”可重新输入；若密码输入正确，则可进行参数设置。设置完成后按 **SET** 进入“SAVE”界面，“YES”下按 **↩** 则保存后退出，“no”下按 **↩** 则不保存直接退出。

Press **SET** at any main menu and get in “PASS” interface, and then press **↩** show “0000”, and enter the code. If you enter a wrong code, it will show “fail” and back to main menu; and if you enter a right code, you can set the parameter. After setting the parameter and



press  , it will show “save” and save the change by pressing  in “yes” interface and quit without save by pressing  in “no” interface.

## 8.4 可设置数据项 Data settings

序号 Num	一级菜单 First menu		二级菜单 Second menu		
	符号 Symbol	含义 Mean	符号 Symbol	含义 Mean	范围 Range
1	BUS	通讯设置 Communication settings	ADDR	通讯地址设置 Address setting	1-247
			Buad	波特率选择 Baud rate	19200、9600、 4800、2400、1200
			Parity	校验选择 Parity	None、Even
2	SyS	系统设置 System settings	PL	网络选择 Network	3P4L:三相四线 3 phase 4 lines 3P3L:三相三线 3 phase 3 lines
			EF.E	复费率选择 Multi-tariff rate	EF:复费率 Multi-tariff rate E:非复费率 No multi-tariff rate
			CoDE	密码设置 Code setting	1-9999
			LED	背光时间设置 Time of light	1-9999
3	In.	变比设置 Transformer settings	Pt	电压变比 Voltage transformer	1-9999
			Ct	电流变比 Current transformer	1-9999

注： Modbus 协议模式可进行 None、Even 切换

Note: Customers can choose None or Even under Modbus protocol,

## 9 通信说明 Communication description

仪表 RS485 通信接口支持 MODBUS-RTU 通信协议，通信口波特率可在 1200bps、2400 bps、4800 bps、9600bps 和 19200 bps 之间设置，校验位为无校验。

仪表的 RS485 通信口要求使用屏蔽双绞线连接，布线时要考虑整个网络的布局：如通信线缆的长度、走向、上位机的位置、网络末端的匹配电阻、通信转换器、网络可扩展性、网络覆盖范围、环境的电磁干扰情况等因素，都要综合考虑。

The meter adapts MODBUS-RTU protocol, and the baud rate can be chosen from 1200bps、2400 bps、4800 bps、9600bps and 19200 bps. The parity is None.

The meter needs shielded twisted pair conductors to connect. Customers should consider the whole network's parameters such like communication wire's length, the direction, communication transformer and network cover range, etc.

注:

在布线工程上要严格按照要求施工;

对于暂时不需要通信的仪表都要将他们连接到 RS-485 网络上, 以便于诊断和测试;

进行 RS-485 电缆连接时, 尽量使用双色双绞线, 所有的 485 通信口 “A” 端接同一种颜色, “B” 端接另一种颜色。

RS-485 总线(从上位机通信口开始到任一被连接的仪表终端通信口)长不超过 1200 米。

Note:

Wiring should follow the wiring requirements;

Connect all the meter in the RS485 net work even some do not need to communication, which is benefit for error checking and testing;

Use two color wires in connecting wires and all the A port use the same color.

No longer than 1200 meters of RS485 bus line.

## 9.1 地址表

仪表支持 MODBUS-RTU 协议中的 03H 命令与 10H 命令, 03H 为读多个寄存器, 10H 为写多个寄存器, 协议数据格式请自行查询。下表为仪表的寄存器地址表:

MODBUS-RTU protocol has 03H and 10H command to read and write registers respectively.

The following chart is registers' address list:

数据地址 Address	数据名称 Variable	长度 Length	读/写 R/W	备注 Notes
0000H	当前总有功电能 Current total electricity	4	R	
0002H	当前总有功尖电能 Current spike electric energy	4	R	
0004H	当前总有功峰电能 Current peak electric energy	4	R	
0006H	当前总有功平电能 Current flat electric energy	4	R	
0008H	当前总有功谷电能 Current valley electric energy	4	R	
000AH	当前正向总有功电能 Current forward active total electric energy	4	R	

000CH	当前正向有功尖电能 Current forward active spike electric energy	4	R	
000EH	当前正向有功峰电能 Current forward active peak electric energy	4	R	
0010H	当前正向有功平电能 Current forward active flat electric energy	4	R	
0012H	当前正向有功谷电能 Current forward active valley electric energy	4	R	
0014H	当前反向有功总电能 Current reversing active total electric energy	4	R	
0016H	当前反向有功尖电能 Current reversing active spike electric energy	4	R	
0018H	当前反向有功峰电能 Current reversing Active peak electric energy	4	R	
001AH	当前反向有功平电能 Current reversing active flat electric energy	4	R	
001CH	当前反向有功谷电能 Current reversing Active valley electric energy	4	R	
001EH	当前总无功电能 Current total reactive electric energy	4	R	
0020H	当前总无功尖电能 Current total reactive spike electric energy	4	R	

0022H	当前总无功峰电能 Current total reactive peak electric energy	4	R	
0024H	当前总无功平电能 Current total reactive flat electric energy	4	R	
0026H	当前总无功谷电能 Current total reactive valley electric energy	4	R	
0028H	当前正向无功总电能 Current forward reactive total electric energy	4	R	
002AH	当前正向无功尖电能 Current forward reactive spike electric energy	4	R	
002CH	当前正向无功峰电能 Current forward reactive spike electric energy	4	R	
002EH	当前正向无功平电能 Current forward reactive flat electric energy	4	R	
0030H	当前正向无功谷电能 Current forward reactive valley electric energy	4	R	
0032H	当前反向无功总电能 Current reversing reactive total electric energy	4	R	
0034H	当前反向无功尖电能 Current reversing reactive spike electric energy	4	R	
0036H	当前反向无功峰电能 Current reversing reactive peak electric energy	4	R	
0038H	当前反向无功平电能 Current reversing reactive flat electric energy	4	R	
003AH	当前反向无功谷电能 Current reversing reactive valley electric energy	4	R	

	electric energy			
003CH	日期时间 Date, time	6	R/W	
003FH 高字节	第一路通讯通信地址 First communication path: Address	1	R/W	1~247
003FH 低字节	第一路通讯波特率 First communication path: Baud rate	1	R/W	1: 9600pbs 2: 4800pbs 3: 2400pbs 4: 1200pbs
0040H	脉冲常数 Pulse constant	2	R	
0041H ... 0046H	4个时区 4 time zones	3×4	R/W	时区表 Time zone table
0047H ... 0052H	1-8时段参数设置信息 1-8period of time Parameters setting information	3×8	R/W	第一套时段表 The first time list
0053H ... 0060H	1-9时段参数设置信息 1-9period of time Parameters setting information	3×9	R/W	第二套时段表 The second time list
0061H	A相电压 Voltage of A phase	2	R	
0062H	B相电压 Voltage of B phase	2	R	
0063H	C相电压 Voltage of C phase	2	R	
0064H	A相电流 Electricity of A phase	2	R	
0065H	B相电流 Electricity of B phase	2	R	
0066H	C相电流 Electricity of C phase	2	R	
0067H-0076H	保留 Reserve	2	R	
0077H	频率 Frequency	2	R	
0078H	A-B线电压 Voltage between A-B	2	R	

0079H	C-B 线电压 Voltage between C-B	2	R	
007AH	A- C 线电压 Voltage between A-C	2	R	
007BH	正向有功最大需量 Forward active maximum demand	2	R	
007CH	发生时间 Time of occurrence for the forward active maximum amount	4	R	
007EH	反向有功最大需量 Reversing active maximum demand	2	R	
007FH	发生时间 Time of occurrence for the reversing active maximum amount	4	R	
0081H	正向无功最大需量 Maximum forward demand for reactive power	2	R	
0082H	发生时间 Time of occurrence for the forward reactive maximum amount	4	R	
0083H	反向无功最大需量 Maximum reversing demand for reactive power	2	R	
0085H	发生时间 Time of occurrence for the reversing reactive maximum amount	4	R	
0087H	A 相正向有功电能 Forward active electric energy of A phase	4	R	
0089H	B 相正向有功电能 Forward active electric energy of B phase	4	R	
008BH	C 相正向有功电能 Forward active electric energy of C phase	4	R	
008DH	电压变比 PT	2	R/W	

	Voltage transfer			
008EH	电流变比 CT Current transfer	2	R/W	
008FH 高字节	失压阈值 Threshold of voltage	1	R/W	
008FH 低字节	失压状态 State of loss voltage	1	R	
0090H	保留 Reserve	2	R	
0091H 高字节	运行状态 1 Running state 1	1	R/W	
0091H 低字节	运行状态 2 Running state 2	1	R/W	
0092H	零序电流 Zero sequence current	2	R	
0093H	电压不平衡度 Voltage imbalance	2	R	单位 unit 0.1%
0094H	电流不平衡度 Current imbalance	2	R	
0095H	第一路通讯 First communication path: 校验位 Testing byte (高 8 位 High 8 bytes) 停止位 Stop byte (低 8 位 Low 8 bytes)	2	R/W	校验位 testing byte: 0: 无校验 none 2: 偶校验 even 停止位 stop byte: 0: 1 位停止位 0: 1 stop byte 1: 2 位停止位 1: 2 stop bytes
0096H	第二路通讯 Second communication	2	R/W	同第一路通讯设置

	path: 通信地址 Address(高 8 位 High 8 bytes) 波特率 Baud rate (低 8 位 Low 8 bytes)			Same as the first communication path
0097H	第二路通讯 Second communication path: 校验位 Testing byte (高 8 位 High 8 bytes) 停止位 Stop byte (低 8 位 Low 8 bytes)	2	R/W	同第一路通讯设置 Same as the first communication path
0098H-00B1	保留 Reserved			
00B2H ... 00BAH	9-14 时段参数设置信息 9-14 period of time Parameters setting information			第一套时段表 The first time list
00BBH ... 00C3H	9-14 时段参数设置信息 9-14 period of time Parameters setting information			第二套时段表 The second time list
00C4H ... 0163H	保留 Reserved			
0164H	A 相有功功率 Active power of A phase	4	R	
0166H	B 相有功功率 Active power of B phase	4	R	
0168H	C 相有功功率 Active power of C phase	4	R	
016AH	总有功功率 Total active power	4	R	



016CH	A相无功功率 Reactive power of A phase	4	R	
016EH	B相无功功率 Reactive power of B phase	4	R	
0170H	C相无功功率 Reactive power of C phase	4	R	
0172H	总无功功率 Total reactive power	4	R	
0174H	A相视在功率 Apparent power of A phase	4	R	
0176H	B相视在功率 Apparent power of b phase	4	R	
0178H	C相视在功率 Apparent power of c phase	4	R	
017AH	总视在功率 Total apparent power	4	R	
017CH	A相功率因数 Power factor of A phase	2	R	
017DH	B相功率因数 Power factor of B phase	2	R	
017EH	C相功率因数 Power factor of C phase	2	R	
017FH	总功率因数 Total power factor	2	R	
0180H	当日正向有功最大需量 Maximum forward active demand a day	2	R	
0181H	发生时间：分、时 Occur time	2	R	
0182H	当日反向有功最大需量 Maximum reversing active demand a day	2	R	
0183H	发生时间：分、时 Occur time	2	R	
0184H	当日正向无功最大需量 Maximum forward reactive demand a day	2	R	

0185H	发生时间：分、时 Occur time	2	R	
0186H	当日反向无功最大需量 Maximum reversing reactive demand a day	2	R	
0187H	发生时间：分、时 Occur time	2	R	
0188H	上1日正向有功最大需量 Maximum forward active demand last day	2	R	
0189H	发生时间：分、时 Occur time	2	R	
018AH	上1日反向有功最大需量 Maximum reversing active demand last day	2	R	
018BH	发生时间：分、时 Occur time	2	R	
018CH	上1日正向无功最大需量 Maximum forward reactive demand last day	2	R	
018DH	发生时间：分、时 Occur time	2	R	
018EH	上1日反向无功最大需量 Maximum reversing reactive demand last day	2	R	
018FH	发生时间：分、时 Occur time	2	R	
0190H	上2日正向有功最大需量 Maximum forward active demand last 2 days	2	R	
0191H	发生时间：分、时 Occur time	2	R	
0192H	上2日反向有功最大需量 Maximum reversing active demand last 2 days	2	R	
0193H	发生时间：分、时 Occur time	2	R	

0194H	上 2 日正向无功最大需量 Maximum forward reactive demand last 2 days	2	R	
0195H	发生时间：分、时 Occur time	2	R	
0196H	上 2 日反向无功最大需量 Maximum reversing reactive demand last 2 days	2	R	
0197H	发生时间：分、时 Occur time	2	R	
0198H	当前正向有功需量 Current forward active demand	2	R	
0199H	当前反向有功需量 Current reversing active demand	2	R	
019AH	当前正向无功需量 Current forward reactive demand	2	R	
019BH	当前反向无功需量 Current reversing reactive demand	2	R	
019BH-01FFH	保留 Reserved			
0200H	A 相电压极大值 Maximum voltage on A phase	2	R	
0201H	发生时间：月、日 Occur date	2	R	
0202H	发生时间：时、分 Occur time	2	R	
0203H	B 相电压极大值及发生时间 Maximum voltage on B phase and occur time	6	R	
0206H	C 相电压极大值及发生时间 Maximum voltage on C phase and occur time	6	R	
0209H	A 相电流极大值及发生时间 Maximum current on A phase and occur time	6	R	
020CH	B 相电流极大值及发生时间 Maximum current on B phase and occur time	6	R	
020FH	C 相电流极大值及发生时间 Maximum current on C phase and occur time	6	R	
0212H	A 相有功功率极大值	4	R	

	Maximum active power on A phase		
0214H	发生时间：月、日 Occur date	2	R
0215H	发生时间：时、分 Occur time	2	R
0216H	B相有功功率极大值及发生时间 Maximum active power on B phase and occur time	8	R
021AH	C相有功功率极大值及发生时间 Maximum active power on C phase and occur time	8	R
021EH	总有功功率极大值及发生时间 Maximum active power and occur time	8	R
0222H	A相无功功率极大值及发生时间 Maximum reactive power on A phase and occur time	8	R
0226H	B相无功功率极大值及发生时间 Maximum reactive power on B phase and occur time	8	R
022AH	C相无功功率极大值及发生时间 Maximum reactive power on C phase and occur time	8	R
022EH	总无功功率极大值及发生时间 Maximum reactive power and occur time	8	R
0232H	A相视在功率极大值及发生时间 Maximum apparent power on A phase and occur time	8	R
0236H	B相视在功率极大值及发生时间 Maximum apparent power on B phase and occur time	8	R
023AH	C相视在功率极大值及发生时间 Maximum apparent power on C phase and occur time	8	R
023EH	总视在功率极大值及发生时间 Maximum apparent power and occur time	8	R
0242H	A相电压极小值及发生时间 Minimum voltage on A phase and occur time	6	R
0245H	B相电压极小值及发生时间 Minimum voltage on B phase and occur time	6	R
0248H	C相电压极小值及发生时间 Minimum voltage on C phase and occur time	6	R

024BH	A相电流极小值及发生时间 Minimum current on A phase and occur time	6	R
024EH	B相电流极小值及发生时间 Minimum current on B phase and occur time	6	R
0251H	C相电流极小值及发生时间 Minimum current on C phase and occur time	6	R
0254H	A相有功功率极小值及发生时间 Minimum active power on A phase and occur time	8	R
0258H	B相有功功率极小值及发生时间 Minimum active power on B phase and occur time	8	R
025CH	C相有功功率极小值及发生时间 Minimum active power on C phase and occur time	8	R
0260H	总有功功率极小值及发生时间 Minimum active power and occur time	8	R
0264H	A相无功功率极小值及发生时间 Minimum reactive power on A phase and occur time	8	R
0268H	B相无功功率极小值及发生时间 Minimum reactive power on B phase and occur time	8	R
026CH	C相无功功率极小值及发生时间 Minimum reactive power on C phase and occur time	8	R
0270H	总无功功率极小值及发生时间 Minimum reactive power and occur time	8	R
0274H	A相视在功率极小值及发生时间 Minimum apparent power on A phase and occur time	8	R
0278H	B相视在功率极小值及发生时间 Minimum apparent power on B phase and occur time	8	R
027EH	C相视在功率极小值及发生时间 Minimum apparent power on C phase and occur time	8	R
0280H	总视在功率极小值及发生时间 Minimum apparent power and occur time	8	R
0285H-1FFFH	保留 Reserve		
2000H	T1 温度 T1 temperature	2	R

2001H	T2 温度 T2 temperature	2	R
2002H	T3 温度 T3 temperature	2	R

## 9.2 历史电能冻结时间设定及历史电能数据

DTSD1352 日冻结时间设定寄存器、月冻结日期设定寄存器。

DTSD1352's registers on frozen by day and by month.

地址 Address	名称 Name	R/W	备注 Note
0121H	日冻结时间 Frozen time by day	R/W	无效（高字节）抄表时（低字节） Null (High byte) Hour(Low byte)
0122H	月冻结时间 Frozen time by month	R/W	抄表日（高字节）抄表时（低字节） Day(High byte) Hour(Low byte)

DTSD1352 能统计上 48 月的历史电能（各费率电能）。DTSD1352 能统计上 90 日的历史电能（各费率电能）。历史电能只能通过块读取，长度为 120 个字节(60 个寄存器)，每块的顺序和内容如下：

DTSD1352 can achieve the history energy statistic in last 48 months and last 90days. (Each tariff rate of energy can be recorded.)The history energy record can only be read by assemblage and the length of whole part is 120 byte (60 registers), and list below is the registers' name:

地址 Address	名称 Name	数据顺序 Data list	名称 Name
1001H	上 1 月电能及需量块 Assemblage of last 1 month demand and energy	0000H	冻结时间：年-月 Frozen time: YY-MM
1002H	上 2 月电能及需量块 Assemblage of last 2 months demand and energy	0001H	冻结时间：日-时 Frozen time: DD-hh
...	...	0002H	正向总有功电能 Total forward active energy
1030H	上 48 月电能及需量块 Assemblage of last 48 months demand and energy	0004H	正向有功尖电能 Spike forward active energy
1101H	上 1 日电能及需量块 Assemblage of last 1 day demand and energy	0006H	正向有功峰电能 Peak forward active energy
1102H	上 2 日电能及需量块 Assemblage of last 2days demand and energy	0008H	正向有功平电能 Flat forward active energy
...	...	000AH	正向有功谷电能 Valley forward active energy
115AH	上 90 日电能及需量块 Assemblage of last 90days demand and energy	000CH	反向总有功电能 Total reversing active energy
		000EH	反向有功尖电能

	Spike reversing active energy
0010H	反向有功峰电能 Peak reversing active energy
0012H	反向有功平电能 Flat reversing active energy
0014H	反向有功谷电能 Valley reversing active energy
0016H	正向总无功电能 Total forward reactive energy
0018H	正向无功尖电能 Spike forward reactive energy
001AH	正向无功峰电能 Peak forward reactive energy
001CH	正向无功平电能 Flat forward reactive energy
001EH	正向无功谷电能 Valley forward reactive energy
0020H	反向总无功电能 Total reversing reactive energy
0022H	反向无功尖电能 Spike reversing reactive energy
0024H	反向无功峰电能 Peak reversing reactive energy
0026H	反向无功平电能 Flat reversing reactive energy
0028H	反向无功谷电能 Valley reversing reactive energy
002AH	A 相有功电能 Active energy on A phase
002CH	B 相有功电能 Active energy on B phase
002EH	C 相有功电能 Active energy on C phase
0030H	正向有功最大需量 Maximum forward active demand
0031H	发生时间：分、时

	Occur time: mm-hh
0032H	发生时间：日、月 Occur time : DD-MM
0033H	反向有功最大需量 Maximum reversing active demand
0034H	发生时间：分、时 Occur time: mm-hh
0035H	发生时间：日、月 Occur time : DD-MM
0036H	正向无功最大需量 Maximum forward reactive demand
0037H	发生时间：分、时 Occur time: mm-hh
0038H	发生时间：日、月 Occur time : DD-MM
0039H	反向无功最大需量 Maximum reversing reactive demand
003AH	发生时间：分、时 Occur time: mm-hh
003BH	发生时间：日、月 Occur time : DD-MM

### 9.3 分次谐波数据

DTSD1352 可选配谐波测量，统计分相 31 次谐波电压电流、总谐波畸变率、分相谐波电压电流、分相谐波有功功率无功功率、分相基波电流电压、分相基波有功功率无功功率。

DTSD1352 has function of harmonic. The function include 31<sup>st</sup> harmonic statistics of voltage and current, harmonic voltage and current of each phase apparently, harmonic active/reactive power of each phase apparently, fundamental voltage and current of each phase apparently and fundamental active/reactive power of each phase apparently.

地址 Addr	名称 Name	长度 Length	R/W	备注 Note
05DDH	THDUa	2	R	分相电压电流总畸变率 Total distortion rate of voltage and current on each phase 整形,保留 2 位小数 Int Keep 3 decimal places
05DEH	THDUb	2	R	
05DFH	THDUc	2	R	
05E0H	THDIa	2	R	
05E1H	THDIb	2	R	
05E2H	THDIc	2	R	
05E3H	THUa	2×30		电压分相 2~31 次谐波含量
0601H	THUb	2×30		



061FH	THUc	2×30		Harmonic voltage on 2 <sup>nd</sup> -31 <sup>st</sup> 整形,保留 2 位小数 Int Keep 3 decimal places
063DH	THIa	2×30		电流分相 2~31 次谐 波含量
065BH	THIb	2×30		
0679H	THIc	2×30		Harmonic current on 2 <sup>nd</sup> -31 <sup>st</sup> 整形,保留 2 位小数 Int Keep 2 decimal places
0697H	A 相基波电压 Fundamental voltage on A phase	2		整形, 保留 1 位小数 Int Keep 1 decimal places
0698H	B 相基波电压 Fundamental voltage on B phase	2		
0699H	C 相基波电压 Fundamental voltage on C phase	2		
069AH	A 相谐波电压 Harmonic voltage on A phase	2		
069BH	B 相谐波电压 Harmonic voltage on B phase	2		
069CH	C 相谐波电压 Harmonic voltage on C phase	2		
069DH	A 相基波电流 Fundamental current on A phase	2		
069EH	B 相基波电流 Fundamental current on B phase	2		
069FH	C 相基波电流 Fundamental current on C phase	2		
06A0H	A 相谐波电流 Harmonic current on A phase	2		
06A1H	B 相谐波电流 Harmonic current on B phase	2		
06A2H	C 相谐波电流 Harmonic current on C phase	2		
06A3H	A 相基波有功功率 Fundamental active power on A phase	2		整形 保留 3 位小数 Int Keep 3 decimal places
06A4H	B 相基波有功功率 Fundamental active power on B phase	2		
06A5H	C 相基波有功功率 Fundamental active power on C	2		

	phase		
06A6H	总基波有功功率 Fundamental active power	2	
06A7H	A 相基波无功功率 Fundamental reactive power on A phase	2	
06A8H	B 相基波无功功率 Fundamental reactive power on B phase	2	
06A9H	C 相基波无功功率 Fundamental reactive power on C phase	2	
06AAH	总基波无功功率 Fundamental reactive power	2	
06ABH	A 相谐波有功功率 Harmonic active power on A phase	2	
06ACH	B 相谐波有功功率 Harmonic active power on B phase	2	
06ADH	C 相谐波有功功率 Harmonic active power on C phase	2	
06AEH	总谐波有功功率 Harmonic active power	2	
06AFH	A 相谐波无功功率 Harmonic reactive power on A phase	2	
06B0H	B 相谐波无功功率 Harmonic reactive power on B phase	2	
06B1H	C 相谐波无功功率 Harmonic reactive power on C phase	2	
06B2H	总谐波无功功率 Harmonic reactive power	2	

### 9.3 SOE 事件记录 SOE record

地址 Address	名称 Name	数据顺序 Data list	名称 Name
3001H	上 1 次事件记录 Last event record	0000H	事件发生：年-月 Occur date: YY-MM
3002H	上 2 次事件记录 Last 2 event record	0001H	事件发生：日-时 Occur time: DD-hh
...	...	0002H	事件发生：分-秒 Occur time: mm-ss
3064H	上 100 次事件记录	0004H	事件编号

	Last 100 event record
--	-----------------------

	Event number
0005H	事件详情 Event details
0006H	预留 Reserve

事件编号 Event num	名称 Name	事件详情 Details	备注 Note
0100/0101	上电/断电事件 Power on/off		
0200	清零事件 Clear	0001	当前电能清零 Clear current energy
		0002	Flash 历史电能清零 Clear history energy on Flash
		0003	最大需量清零 Clear maximum demand
		0004	历史电能清零 Clear history energy
		0005	极值清零 Clear maximum value on a period
		0006	全清零 Clear out
0300	DO 动作记录 DO action	0000	DO 断开 off
		0001	DO 闭合 on
0400	UI 事件记录 UI record	UI 状态	Bit0:A 相过压; Over-voltage on A phase Bit1:B 相过压; Over-voltage on B phase Bit2:C 相过压; Over-voltage on C phase Bit3:A 相失压; Lose-voltage on A phase Bit4:B 相失压; Lose-voltage on B phase Bit5:C 相失压; Lose-voltage on C phase Bit6:A 相逆向; Reversing on A phase Bit7:B 相逆向; Reversing on B phase Bit8:C 相逆向; Reversing on C phase

		Bit9:A 相电流过高; Over current on A phase Bit10:B 相电流过高; Over current on B phase Bit11:C 相电流过高; Over current on C phase Bit12:A 相电流过低; Low current on A phase Bit13:B 相电流过低; Low current on B phase Bit14:C 相电流过低; Low current on C phase
0700	校时 Time calibration	

如当前仪表地址为 001，读取上 1 条事件记录主站发送：01 03 30 01 00 06 9B 08，从站回复为：01 03 0C 12 01 08 0A 01 01（18 年 1 月 8 日 10 时 1 分 1 秒）01 00（上电）00 00（上电事件无事件详情）00 00（预留） 80 23。

Example: The address is 001 at present, and we send the code: 01 03 30 01 00 06 9B 08 to get the last event record, and the slave station will give back: 01 03 0C 12 01 08 0A 01 01 (2018/1/8 10:1:1) 01 00 (powered) 00 00 (no details) 00 00 (reserved) 80 23

总部：安科瑞电气股份有限公司

地址：上海市嘉定区育绿路 253 号

电话：(86)021-69158300 69158301 69158302

传真：(86)021-69158303

服务热线：800-820-6632

网址：[www.acrel.cn](http://www.acrel.cn)

邮箱：[ACREL001@vip.163.com](mailto:ACREL001@vip.163.com)

邮编：201801

生产基地：江苏安科瑞电器制造有限公司

地址：江阴市南闸街道东盟路 5 号

电话(传真)：(86)0510-86179970

邮箱：[JY-ACREL001@vip.163.com](mailto:JY-ACREL001@vip.163.com)

邮编：214405